

New dot peen marking gun e10-p123

Robust and reliable

- Cast aluminum body and handle for robustness and lightness
- Rigid and stable one-piece front plate perfectly suited for industrial environment

Comfortable

- Low vibrations during marking
- Minimal noise
- Back face support providing great stability
- Light weight

High performance

- Constant precision and quality
- High speed marking
- Powerful system for deep marking
- Marking on parts up to 62HRC

User-friendly

- Easy front plate adjustment with 4 predefined positions
- Handle base designed to guarantee perfect stability
- Removable handle hood for easy maintenance



V-groove front plate allowing marking on cylindrical shape parts



Ergonomic and robust back face support



Stainless steel spring string relief for cable protection



LEDs

- Visualization of the marking area

E10 CONTROLLER



e10

- Color screen
- USB connection for simple transfer of marking files
- Connectivity (usb, ethernet etc.)
- Fully programmable
- Cutting edge Microprocessor: quick start and smooth browsing
- Marking history and auto diagnostic functions
- All marking types (DataMatrix, angular, circular, alphanumeric, logos etc.)
- Industrial membrane keyboard
- Fully enclosed controller (IP40): no openings or fans
- 100% compatible with the previous machine generation



Color screen



USB connection on the front panel: for simple transfer of marking files



Full connectivity : suited to adapt to different communication protocols (some are optional)

MARKING SAMPLES



MECHANICAL TECHNICAL FEATURES

p 123

Marking window	120 x 25 mm / 4.7 x 1 inches or 120 x 40 mm / 4.7 x 1.6 inches
Weight	3,7 kg
Robotic cable	7,5 m (10 m or 15 m in option)
Stylus	Carbide
Marking of cylindrical parts	V-groove front plate
Setup assistance	Position memory front plate
Lighting	LED lighting of the marking field

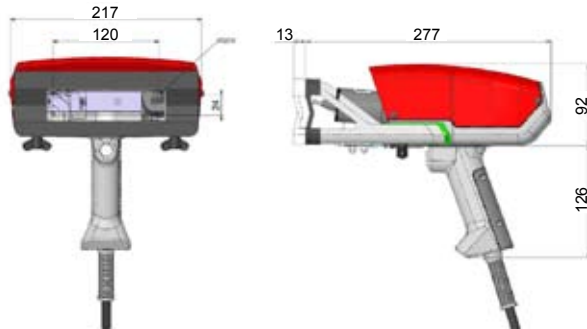

Marking window 120 x 25 mm / 4.7 x 1 inches

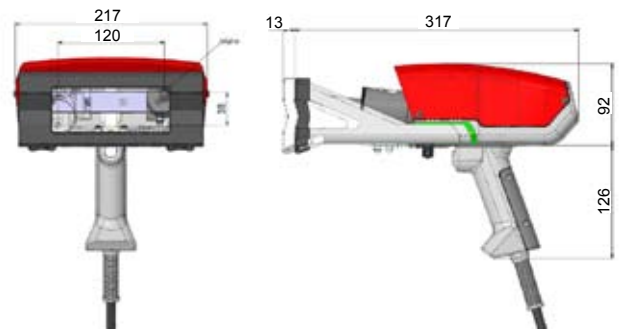

Marking window 120 x 40 mm / 4.7 x 1.6 inches

MARKING AND MOBILITY

With the **CART** option, you get access to **movable** and complete marking system. With or without battery, the cart option allows marking of **larger parts**.

Strong base, battery weight split on wheel-axis, handles covered by foam grip allows the Battery Cart easy movement and a great mobility.

The battery has large autonomy, and its charge allows outdoor work.



OPTIONS



Magnetic clamping



Column / support plate



Hooking ring + balancer



Bar-code and Data Matrix reader



Maintenance kit

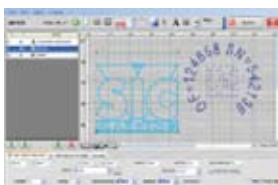

PC-based software



Booster card for deep marking



SIC Marking®

13, route de Limonest
Zac de la Braille
69380 Lissieu - France
Tél. : +33 (0)4 72 54 80 00
Fax : +33 (0)4 78 47 39 40
www.sic-marking.com
info@sic-marking.com

